



Intelligent Brake-Systems



**Know-How & Quality
from IBS**

Electrohydraulic Thrusters

acc. to DIN 15 430



Electrohydraulic Thrusters

acc. to DIN 15 430

**INDUSTRIAL BRAKES · THRUSTERS · PRESSURE OIL UNITS · COUPLINGS · HYDRAULIC BUFFERS
CELLULAR BUFFERS · RAIL CLAMPS · STORM PROTECTION · SHEAVES · REPAIR · SERVICE**



Ed 230/50



Ed 300/50

Additional Equipment:

- Limit Switch (mechanical or inductive)
- Throttle Valve – for stepless reduction of the thruster recoil speed
- Fast Switching – when normal piston lowering time is too long
- Brake Spring (c-spring) – for brake application and control of the brake force
- Re-setting spring, same mode of operation like c-spring with smaller resetting forces
- Damping Spring (d-spring) – to damp random oscillations of the brake (only effective in conjunction with a c-spring)
- Heating for applications where the ambient temperature is less than -25°C

The thrusters meet all DIN requirements

Installation:

Vertical, Horizontal or In-between possible

Motor:

Double Pole Squirrel Cage. Enclosure to IP65.
Insulation to VDE 0530 Class F.

Voltage and Frequency:

Standard Voltage 230V/400V at 50 Hz, or 290/500V at 50 Hz.
All other ac voltages and frequencies are available.

Service Conditions:

All our thrusters are suitable for continuous Running in ambient temperatures up to 50°C. (service conditions S1 – VDE 0530)

Switching Frequency:

Suitable for up to 2000 switch operations per hour.

Ambient Temperature:

From -25°C to +50°C



Ed 1250/60

Technical Description



Abb. 1: Thruster acc. to DIN 15 430 (Type Ed 800/60)

Electrohydraulic thrusters are compact closed systems, consisting of an electric motor and a hydraulic unit. In the switched-on state the electric motor in the lower part of the housing drives the impeller of the hydraulic unit above. The produced hydraulic pressure delivers the working fluid under the piston that pushes the piston rod to the stroke end. In the switched-off state or by power cut the pump stops operating, the oil pressure decrease very quickly and the piston rod returns to its start position.

A fast return of the piston rod can be reached when inserting a re-setting spring (similar to a brake spring) internally or against an external load or using a fast switching when normal piston lowering time is too long.

The hydraulic unit is in a closed housing together with the tank. The oil can be checked and refilled from an external oil filler inlet. The thrusters are supplied ready for assembly with finish coating and filled with oil. They have to be fixed with bolts in the holes of the lug and in piston rod head.

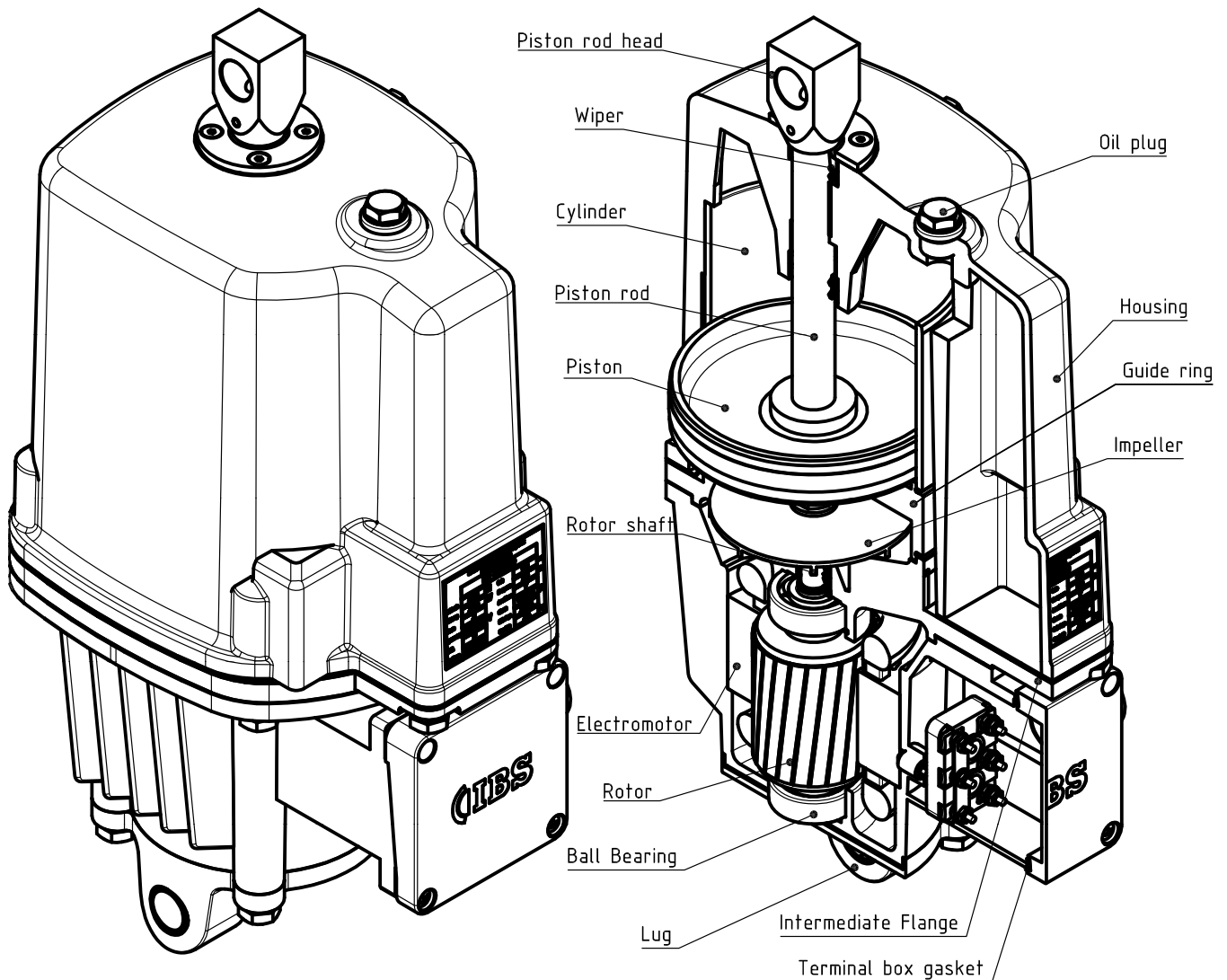
The piston stroke is either determined by a limit stop positioned within the thruster housing or on the outside of the unit.

Application of IBS thruster

- as brake lifter to release and apply to all types of brakes, for example on cranes, conveyors, excavators, roller adjusting devices, standing machines and transport systems
- to operate pressure rollers, blocking devices and distributions guides on rolling mill trains, etc.
- to connect mechanical couplings
- for valve and flap controls, etc.

Characteristics of IBS thruster

- lifting forces from 230 to 3000 N
- 50 mm and 60 mm piston strokes on standard units, longer strokes of up to 300 mm on demand
- short piston lifting and lowering times
- robust construction, therefore particularly suitable for heavy duty and rough operation
- optional motor rotation direction because the impeller pump delivers oil in each direction
- designed for continuous operation (100% on-time) and high switching rate
- no excess loading of the electric motor in case of overload and stroke limitation
- not sensitive to voltage fluctuations
- all units can be supplied with protection mode IP 66 and tropicalized
- piston lowering and lifting time variable by mounting a lowering or lifting rate control valve
- additional adjusting or brake springs can be fitted to all units
- with a normal oil filling the thrusters can be operated at ambient temperatures from -25°C to $+50^{\circ}\text{C}$; with a special oil filling down to -30°C
- additional damping springs are necessary on all units used for adjustable brake controls (e.g. when the lifting motor speed is to be reduced to approx. 20% of the rated speed)
- every unit can be installed vertically, in-between or horizontally and is nearly maintenance free

Electrical Equipment

- Motor:** Two-pole, three-phase, cage motors are fitted in all IBS thrusters. The insulation class of all motors supplied is F - VDE 0530 – the temperature-rise limit of the motor is therefore 150° C.
- Protection mode DIN 40 050:** Delivery will be made with safety class IP66. Standard thrusters are suitable for use in the tropics.
- Voltage/Frequency:** The standard thruster is designed for three-phase current 400-480 Volt, 50/60 Hz or for 500 Volt, 50 Hz. Units for all other three-phase voltages and frequencies are also available. Nine poles, special design terminal board's can be supplied, too. All motor terminal boxes are fitted with an IPON M25x1.5 watertight cable entry.
- Operating mode:** All thrusters are approved for 100% On-time operation (hydraulic operating mode S1 – VDE 0530) at ambient temperatures of up to 40° C.
- Switching rate:** Under normal conditions, all thrusters are designed for up to 2,000 switching operations per hour.
- Rapid lowering circuit:** If the normal piston lowering time is found not to be adequate, it can be reduced by connecting three capacitors in parallel. This shunt connection reduces the deceleration time when the electric motor is switched off. As a result, the oil pressure decreases rapidly. In this case, the thruster must be controlled by a separate relay.
- Limit switch:** All thrusters can be fitted with limit switches on request.

Type	Force N	Stroke mm	Frequency Hz	Voltage V	Current A	Power W	Weight kg
Ed 230/ 50	230	50	50/60	400 - 480	0.5 – 0.6	165	10
Ed 300/ 50	300	50	50/60	400 - 480	0.5 – 0.6	200	14
Ed 500/ 60	500	60	50/60	400 - 480	0.5 – 0.6	210	21
Ed 800/ 60	800	60	50/60	400 - 480	0.7 – 0.8	330	24
Ed 1250/ 60	1250	60	50/60	400 - 480	0.9 – 1.2	330	39
Ed 1850/ 60	1850	60	50/60	400 – 480	1.0 – 1.3	450	39
Ed 2000/ 60	2000	60	50/60	400 - 480	1.0 – 1.3	450	39
Ed 3000/ 60	3000	60	50/60	400 - 480	1.1 – 1.4	550	40
Ed 500/ 120	500	120	50/60	400 - 480	0.5 – 0.6	210	26
Ed 800/ 120	800	120	50/60	400 - 480	0.7 – 0.8	330	27
Ed 1250/ 120	1250	120	50/60	400 - 480	0.9 – 1.2	330	39
Ed 1850/ 160	1850	155	50/60	400 – 480	1.0 – 1.3	450	40
Ed 2000/ 120	2000	120	50/60	400 - 480	1.0 – 1.3	450	39
Ed 3000/ 120	3000	120	50/60	400 - 480	1.0 – 1.4	550	40

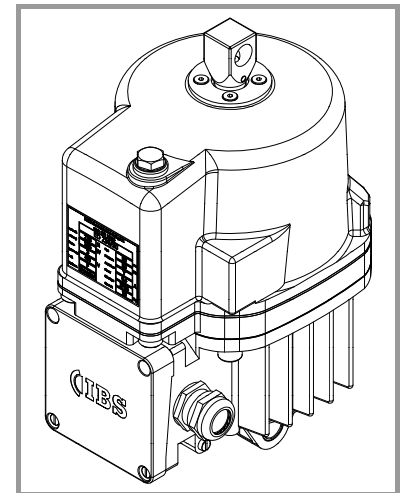
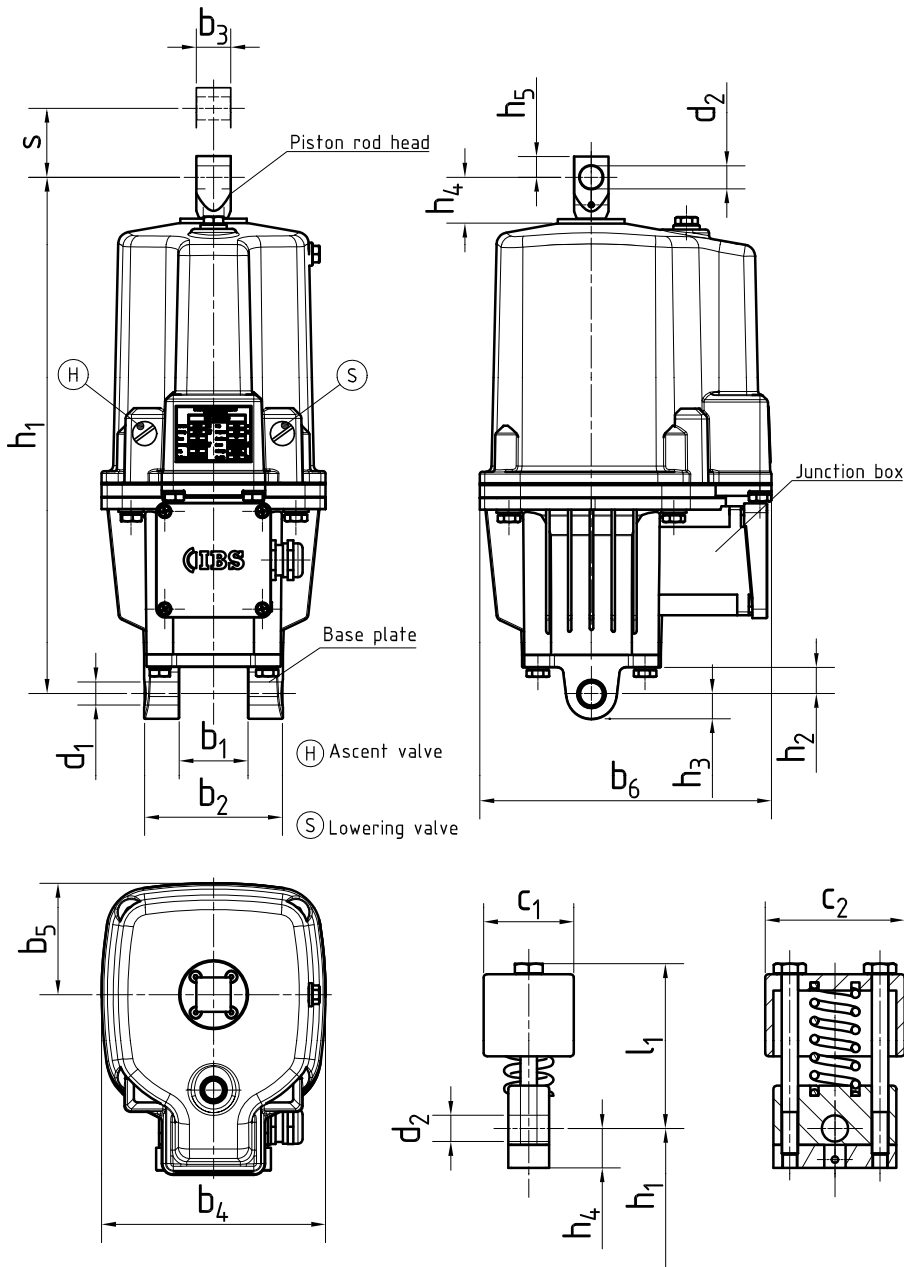

Ed 230/50

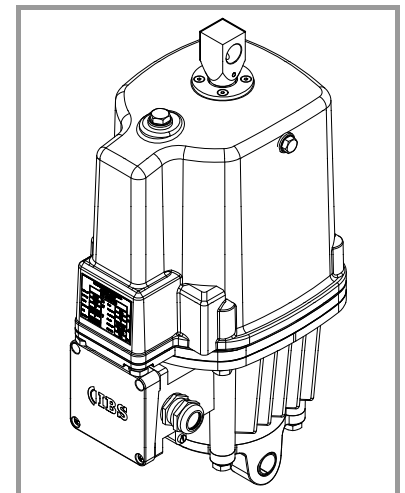

Ed 800/60

Abb. 2: Electrohydraulic Thruster size Ed 230-50 till Ed 800-120

All Dimensions in [mm]

Type	s	b ₁	b ₂	b ₃	b ₄	b ₅	b ₆	c ₁	c ₂	d ₁ ²⁾	d ₂ ¹⁾	h ₁	h ₂	h ₃	h ₅	l ₁
Ed 230/50	50	40	80	20	160	80	200	55	85	16	16	286	20	16	12	100
Ed 300/50	50	40	80	25	160	80	197	55	85	16	16	370	18	16	15	100
Ed 500/60	60	60	120	30	195	97	254	55	85	20	20	435	23	22	18	100
Ed 500/120	120	60	120	30	195	97	254	-	-	20	20	515	23	22	18	-
Ed 800/60	60	60	120	30	195	97	254	55	85	20	20	450	23	22	18	100
Ed 800/120	120	60	120	30	195	97	254	-	-	20	20	530	23	22	18	-

1) Tolerance: +0.1 – 2) Tolerance: +0.15 / +0.25

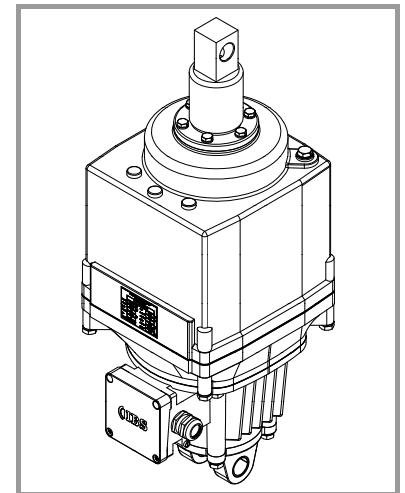
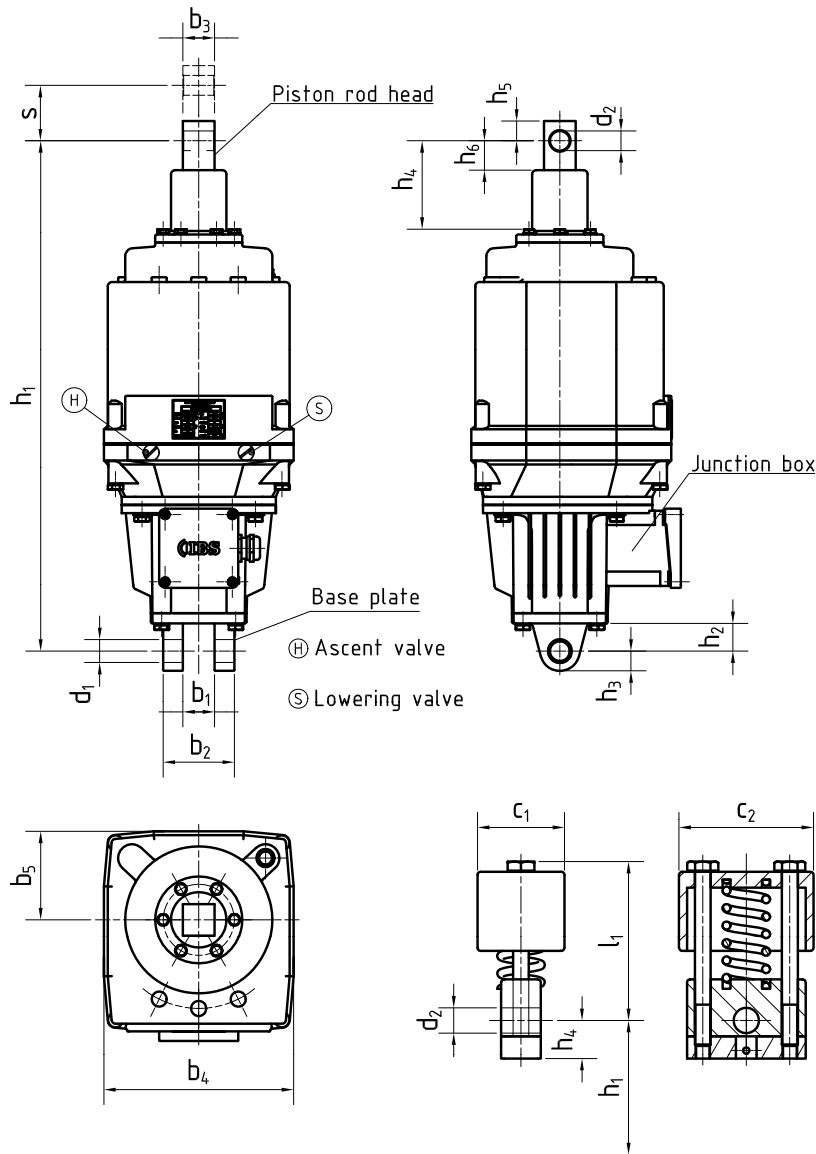

Ed 1250/60

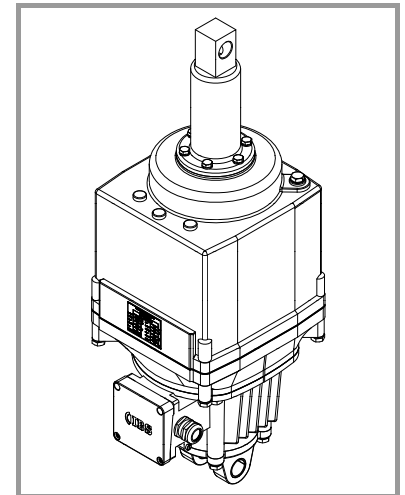

Ed 1250/120

Abb. 3: Electrohydraulic Thruster size Ed 1250-60 till Ed 3000-120

All Dimensions in [mm]

Type	s	b ₁	b ₂	b ₃	b ₄	b ₅	b ₆	c ₁	c ₂	d ₁ ²⁾	d ₂ ¹⁾	h ₁	h ₂	h ₃	h ₄	h ₅	h ₆	l ₁
Ed 1250/ 60	60	40	90	40	240	112	260	80	130	25	25	645	35	25	117	25	38	147
Ed 1250/ 120	120	40	90	40	240	112	260	–	–	25	25	705	35	25	177	25	38	–
Ed 1850/ 60	60	80	160	40	240	112	260	80	130	27	25	600	44	25	76	25	42	147
Ed 1850/ 160	155	80	160	40	240	112	260	–	–	27	25	700	44	25	176	25	42	–
Ed 2000/ 60	60	40	90	40	240	112	260	80	130	25	25	645	35	25	117	25	38	147
Ed 2000/ 120	120	40	90	40	240	112	260	–	–	25	25	705	35	25	177	25	38	–
Ed 3000/ 60	60	40	90	40	240	112	260	80	130	25	25	645	35	25	117	25	38	147
Ed 3000/ 120	120	40	90	40	240	112	260	–	–	25	25	705	35	25	177	25	38	–

1) Tolerance: +0.1 – 2) Tolerance: +0.15 / +0.25

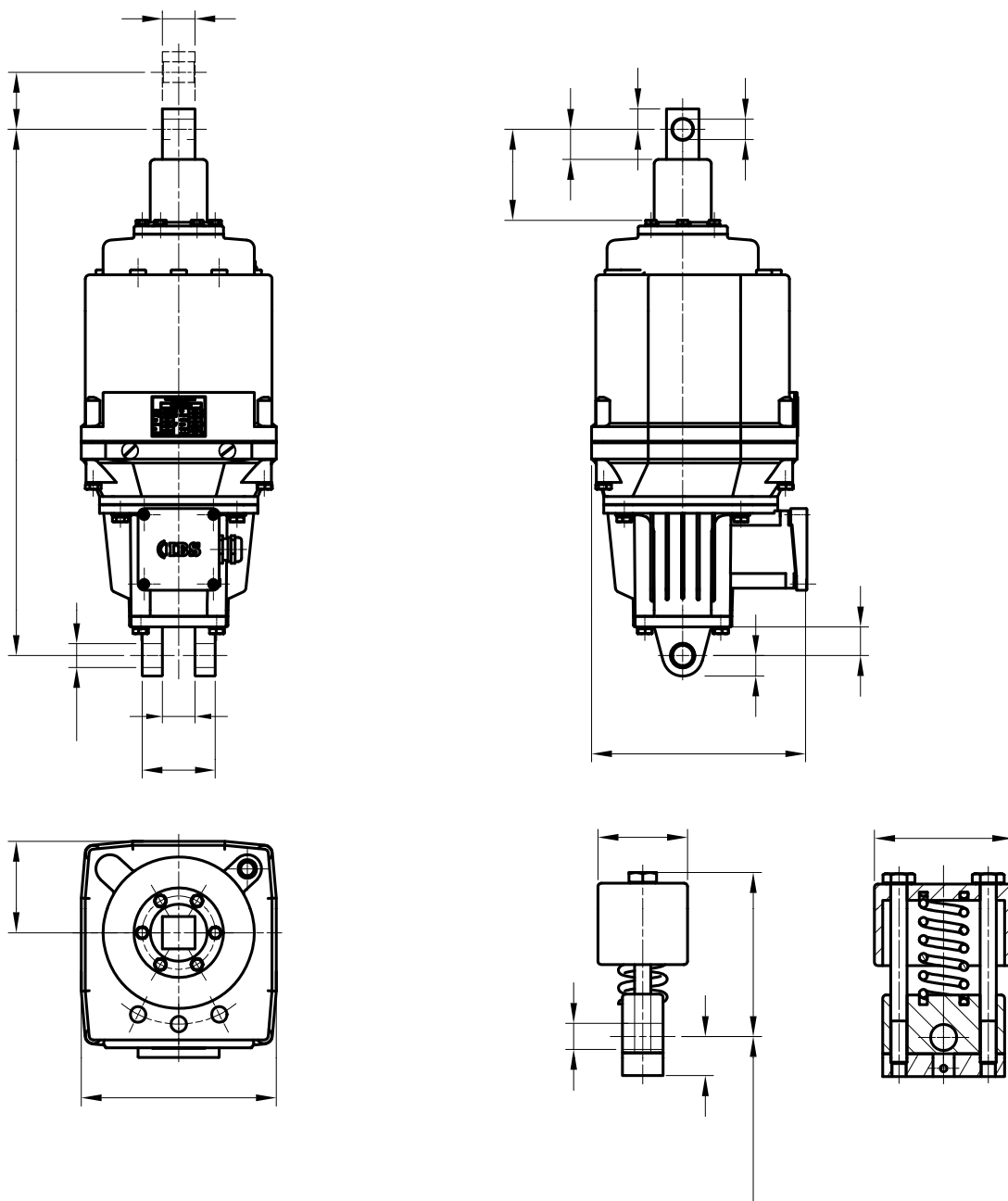

Please indicate your desired dimensions based on above drawing:

Type:		Miscellaneous Requirements:
Force:	N	
Stroke:	mm	
Voltage:	V	
Frequency:	Hz	
c-spring (Braking spring):	<input type="checkbox"/> yes <input type="checkbox"/> no	
d-spring (Damping spring):	<input type="checkbox"/> yes <input type="checkbox"/> no	
H-valve (Lifting valve):	<input type="checkbox"/> yes <input type="checkbox"/> no	
S-valve (Lowering valve):	<input type="checkbox"/> yes <input type="checkbox"/> no	